

## HPT-WH-25ES SCALE PALLET TRUCK

- ◆ Heavy duty pallet truck with built-in scale 2500kg capacity; 500g accuracy.
- ◆ Electronic indicator with 32mm high red LED display. Four load cells ensure accurate readings in kg or lb.
- ◆ Well designed structure. Standard 540mm fork width (rather than 570mm). Low profile 78mm min. fork height.
- ◆ Long life internal battery. Rechargeable 6V/4Ah battery, 40 hours operation.



### ◆ 4 load cells inner weighing structure

Up to 2500kg, readings in kg or lb. 4 built-in load cells ensured accuracy. Accuracy  $\pm 0.5\%$  (500g)



### ◆ Casted galvanized pump

Durable forks made from 4mm thickness steel



### ◆ High Precision multi-function LED screen

7 function keys, simple and convenient operation. 6-digit 32mm LED display, 7 state indicator lamps. Long service life and shock resistance.

Automatic screen protection and automatic shutdown energy-saving function. Tare / Hold / Accumulation (of pallet weight) / Counting mode / Unit switchable

Feature	Model	WH-25ES		
1.1 Capacity		kg		2500
1.2 Pump type				Integrated
1.3 Accuracy		%		$\pm 0.5$
Wheel				
2.1 Wheel(drive/load) Type				PU
2.2 Size of steering wheel	$\Phi D$	mm		180*50
2.4 Size of Loading wheel(double wheel)	$\Phi d$	mm		70*70
Dimensions				
3.1 Lifting height	H	mm		120
3.2 Max. fork lifting height	h	mm		198
3.3 Lowered height of fork	H1	mm		78
3.4 Fork outside distance	W	mm		540
3.5 Fork length	L	mm		1150
3.6 Fork width	S	mm		160
3.7 Weight		kg		96
Battery				
4.1 Battery voltage		V		6
4.2 Battery capacity		Ah		4
	Remark			Standard

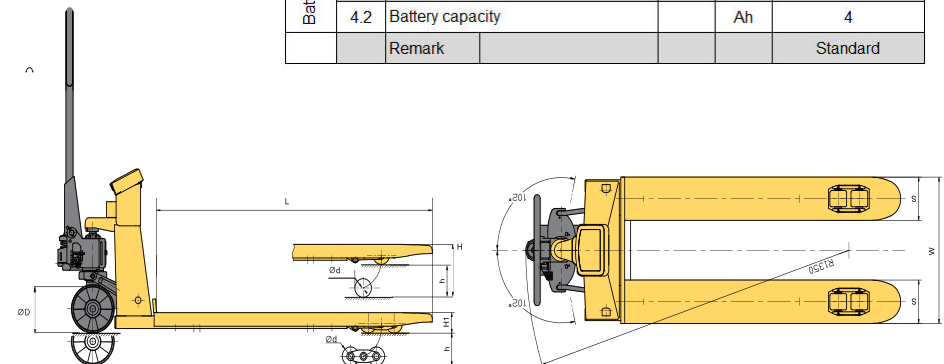

We provide a nationwide 2-3 day delivery service with next day delivery available on request.  
All of our products come with a twelve month return to base limited warranty

PallettrucksUK.co.uk is a trading name of Midland Bearings Ltd  
Registered in England and Wales  
Company Number 02839330 - VAT Registration Number GB 753996769