

SEMI ELECTRIC HIGH LIFT PALLET TRUCK



For piece work and on production lines, high lift pallet trucks can save time, money and reduce injury caused by repetitive strains and lifting, when loading and unloading pallets.

The electric high lift pallet truck saves time, minimises effort and can be placed close to a staff member.

Electric-operated hydraulic pump unit with 1000kg capacity

Heavy duty steel construction with epoxy powder coated finish to give greater anti-corrosion resistance.

Pallet truck is locked to the floor when raised to 400mm and above.

Polyurethane rollers and wheels fitted as standard

Battery and charger are included



Suitable for open bottom Pallets and skids only



MODEL		EX10	
1.1	Capacity	kg	1000
1.2	Min. fork height	H mm	85
1.3	Max.fork height	h mm	800
1.4	Size of fork	s mm	160x50
1.5	Fork overall width	W mm	540
1.6	Fork length	L mm	1150
1.7	Size of load wheel	Φd mm	80x70
1.8	Load wheel		Nylon/PU
1.9	Size of steering wheel	ΦD mm	180x50
1.10	Steering wheel		Nylon/PU/Rubber
1.11	Battery		12V/65Ah
1.12	Lifting motor power	kw	0.8
1.13	Weight	kg	145
1.14	Material		NORMAL

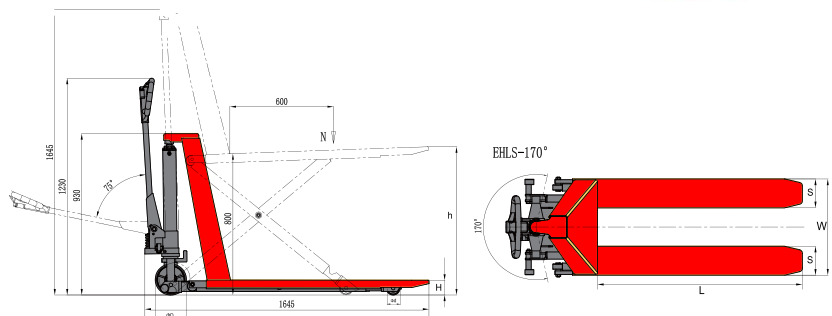

Unit 33, Second Avenue
Pensnett Trading Estate,
Kingswinford,
West Midlands, DY6 7UG

Tel: 0845-519-2700
Fax: 0845-519-2800
sales@PallettrucksUK.co.uk